

**Average Current-Mode Control with Leading Phase Admittance Cancellation Principle for
Single Phase AC-DC Boost converter**

Mukeshkumar Mishra

Electrical Engineering, University of Mumbai.

Shree Krishna jyot apt.

004,B, shirgaon badlapur 421503

Mimukesh123@gmail.com

Abstract

This paper presents an advanced Average Current-Mode Control (ACMC) technique for single phase AC-DC Boost Converter with Reactive Power Control. The leading phase admittance cancellation (LPAC) principle has been proposed to eliminate the current phase lead phenomenon. It results in reduction of the current control loop bandwidth requirement for a given line frequency. These features allow using relatively slow-switching power devices such as IGBT. Thus it can be used for higher ac line frequency such as in aircraft power system (360-800Hz). A theoretical principle & system modeling for bidirectional Boost converter are presented which can be used as shunt active filter for Harmonic Compensation, independently of the converter operation as an ac-dc converter.

Keywords- Power Factor Correction (PFC), Average Current-Mode Control (ACMC), Active Power Filter.

Introduction

Single phase ac-dc static power conversation involves shaping of a sinusoidal ac line voltage waveform into a dc voltage with a relatively very small ac component. Rectification based on traditional diode rectifier capacitive and inductive filters draws non-sinusoidal and rich in harmonic current from ac line. As the number of electronic equipment increases every year, the problem of line current harmonic grows in its significance.

Significant reduction of current harmonics in single-phase circuits can only be achieved by using rectifiers based on switch mode power converters. These converters can be designed to emulate a resistive load and, therefore, produce very little distortion of the current. By using pulse-width modulation or other modulation techniques, these converters draw a nearly sinusoidal current from the ac line in phase with the line voltage. As a result, the rectifier operates with very low current harmonic distortion and very high, practically unity power factor. This technique is commonly known as power factor correction (PFC). The existing PFC technology is based on the boost converter topology with average-current-mode control with pulse width modulation (PWM) controlled converter. At the lower power ratings, MOSFETs are used as switching power devices because of their low conduction losses and high switching speed. For medium and high power applications, IGBTs can be used in PWM converter with switching frequency up to 30 kHz.

Generally to decrease the distortion in line current due to switching action of power devices, a switching frequency is kept at least 1000 times the line frequency. So the application of IGBTs in converter at higher line frequency such as in aircraft power system is fails due there slow switching speed.

In this paper, the LPAC method is introduced to relax the switching speed of converter and thus it also improves the performance of ACMC technique without any great change in their realization circuit. So before going to LPAC method, let we see what is the existing ACMC technique using for converter control.

Average current mode control

The boost topology is a popular choice for a single-phase ac-dc pre-regulator with high power factor and low harmonic distortion of line ac current. The recently proposed ACMC has been widely used in PFC application. The basic control scheme of Bidirectional Boost Converter is shown in Fig.1

The control method works on the following principle: The inductor current of the converter i_L is sensed by a resistor R_s and compared with a control voltage v_c that represents the required average value of the inductor current. The difference is amplified by the compensator comprising of R_i , R_f , C_{fz} and C_{fp} . The output of the amplifier is compared to a triangular PWM signal v_m at the comparator inputs to generate switching control signals for the converter.

In a boost converter example given in this paper, the switched variable is voltage applied to output dc link capacitor or current flowing through an input inductor. The boost PFC converter operating in continuous conduction mode requires line current sensing and output voltage feedback loop. The current controller (Fig.2) is a PI type controller. The control ensures that the average value of switched variable achieves its desired reference value within one switching cycle, hence the name one cycle control.

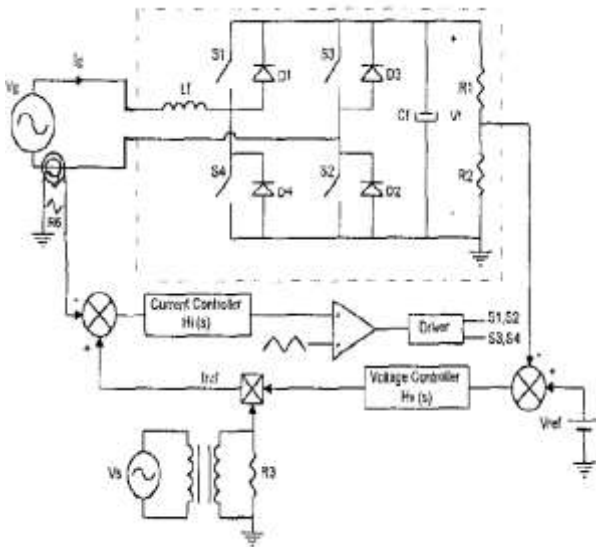

Fig 1: Control Scheme of Bidirectional Boost Converter

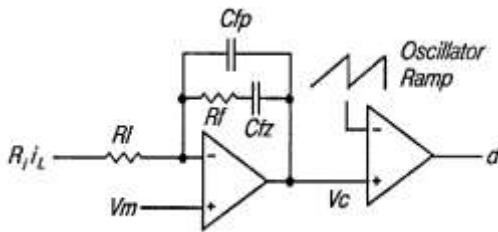

Fig 2: Current loop controller

The bandwidth of the current controller should be high enough to pass all significant harmonics of rectifier sine wave. For that the loop crossover frequency to line frequency ratio should be high to at least 150. The frequency response of current loop controller is shown in Fig.3

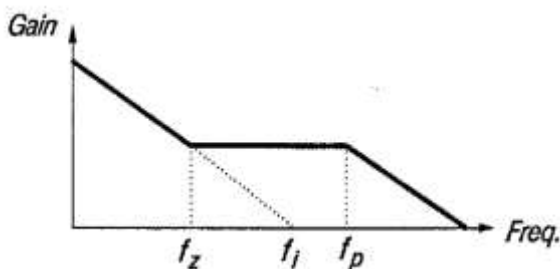

Fig 3: Frequency response of Current loop controller

If this ratio is much smaller, a zero-crossing distortion of line current waveform appears due to the leading phase of the current relative to the line voltage. This leading phase is a result of control action of the current loop compensation scheme. A PFC converter with a zero-crossing distortion of the line current may not be able to meet harmonic distortion requirement. The zero-crossing distortion is not significant in bidirectional converter, but it has to be taking into account for unidirectional converter.

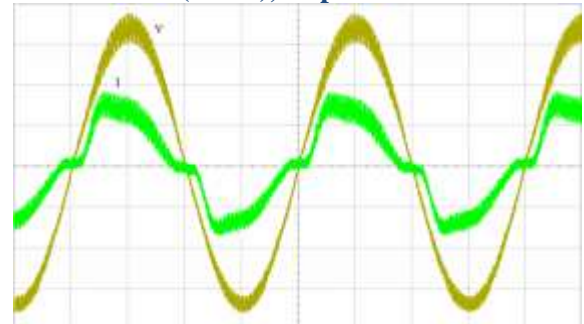

Fig 4: Zero-crossing distortion

System modeling

In Bidirectional PFC Boost converter, an input filter capacitor at the ac line terminals is commonly used to provide a low-impedance path for the inductor current switching ripple in order to reduce propagation of the switching noise into the line. The required filtering capacitance is a function of the converter switching frequency and does not depend on the line frequency. However, this capacitor does affect the total current drawn from the line. Reactive current drawn by this capacitor is proportional to the line frequency. Because of this current, power factor of the converter is less than unity even if the converter without the filtering capacitor operates with unity power factor. At the utility line frequency (50-60 Hz), this current is relatively small and does not cause noticeable power factor degradation. However, in applications with much higher line frequencies such as in aircraft power systems (360–800 Hz), the input capacitor current becomes significant. For example, a 1.5-μF input capacitor typical for a 500W converter draws a current of only 113 mA from a 240-V, 50-Hz line but as much as 0.8 A at 360 Hz, which causes a 21° phase shift of the total current at full load and even larger phase shift at a lower load.

Traditional design of a PFC boost converter utilizes a two-loop control structure (Fig. 5), with an outer voltage-regulating control loop providing reference to an inner Current-shaping loop.

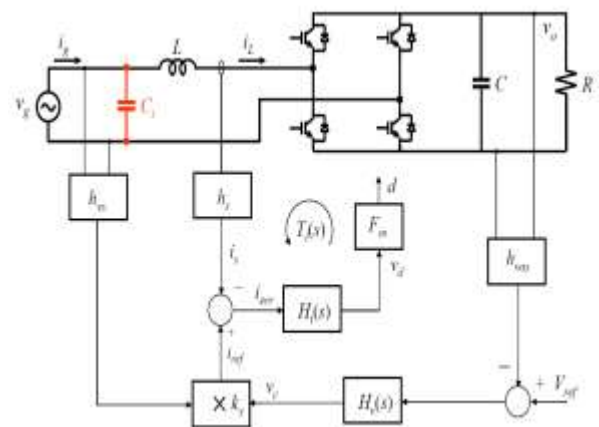

Fig 5: Full-bridge PFC converter with an input filter capacitor

H_i —current loop compensator, H_v —voltage loop compensator,

F_m —modulator gain, k_x —multiplier gain,

h_s —current sensor gain,

h_{vs} and h_{vos} —voltage sensors gain.

In practice, the dc link capacitance C is large enough such that it could be treated as a voltage source. Under this assumption, dc voltage V_o and the voltage loop compensator output V_c are constant values. Then, the dynamic model of the converter is described by the block diagram in Fig. 2.2. The power stage line-to-current and control-to-current transfer functions are

$$G_u(s) = \frac{1}{r + sL} \quad \text{and} \quad G_{vd}(s) = \frac{2V_o}{r + sL} \quad (1)$$

where r is an equivalent resistance of the current path. The compensator is a PI-type controller with the zero placed at or near the loop crossover frequency:

$$H_i(s) = \frac{\omega_z \left(1 + \frac{s}{\omega_z}\right)}{s \left(1 + \frac{s}{\omega_p}\right)} \quad (2)$$

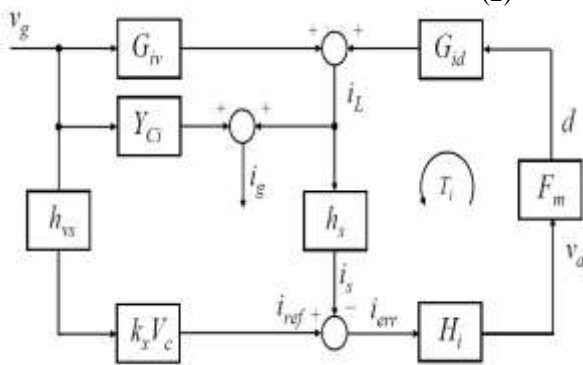

Fig 6: Current loop control diagram of the converter

From Fig. 6, the total input admittance of converter is

$$Y(s) = \frac{i_g(s)}{v_g(s)} = \frac{G_{IV}}{1 + T_i} + \frac{G_{id} F_m H_i}{1 + T_i} k_x V_c h_{vs} + Y_{Ci} \quad (3)$$

Where T_i is the current loop gain:

$$T_i = G_{id} F_m H_i h_s \quad (4)$$

According to (3), the total input admittance of the converter can be represented by two admittance branches $Y_1(s)$, $Y_2(s)$ and the input capacitor C_i (Fig. 7):

$$Y(s) = Y_1(s) + Y_2(s) + Y_{Ci}(s) \quad (5)$$

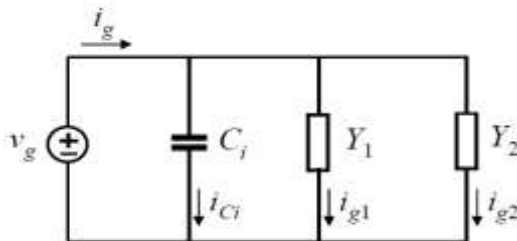

Fig 7: Input admittance of the converter with the input filter capacitor

Below the current loop crossover frequency, neglecting r ,

$$Y_1(s) = \frac{s}{2V_o F_m h_s \omega_z \left(1 + \frac{s}{\omega_z}\right)} \quad (6)$$

$$Y_2(s) = \frac{k_x V_c h_{vs}}{h_s} = \frac{I_g}{V_g} = \frac{P_g}{V_g^2} \quad (7)$$

$$Y_{Ci}(s) = s C_i \quad (8)$$

Component $Y_2(s)$ is the closed-loop current-reference-to-current transfer function (current reference term), which provides desired input admittance magnitude with zero phase below crossover frequency of the loop gain T_i . This branch of the input admittance draws a current in phase with the line voltage, with the magnitude determined by V_c , which corresponds to the load power. Component $Y_1(s)$ is the closed-loop voltage to current transfer function (leading-phase admittance term) plus admittance of input filter capacitor $Y_{Ci}(s)$, which has a 90° leading phase below the crossover frequency (Fig. 8). This branch draws a leading-phase current, which is independent of the converter load and increases with the line frequency for a given current loop bandwidth. This is the reason why the current phase lead effect is observed at higher frequencies, which causes the zero-crossing distortion of the line current and increased harmonic content.

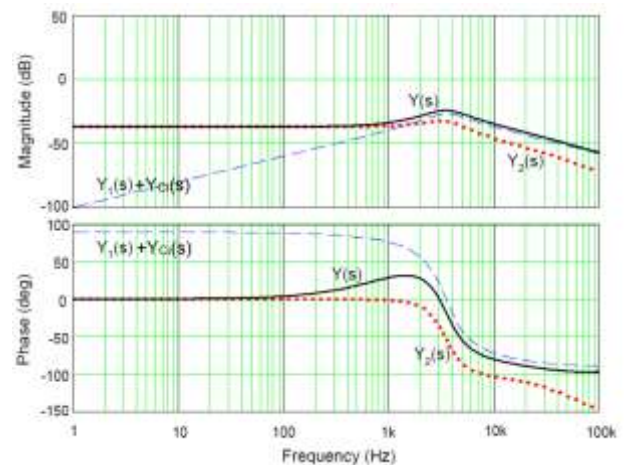

Fig 8: Closed-loop input admittance and its components

Leading phase admittance cancellation

From the discussion above, it is clear that we need to compensate the effect of admittance component $Y_1(s)$ in order to eliminate the current phase lead and the resulting zero-crossing distortion. The leading-phase admittance cancellation (LPAC) method uses an additional term $Y_3(s)$ in the admittance equation (5) to cancel the leading-phase term $Y_1(s)$. Then, the current reference term is left as the only one that determines the magnitude and phase of the line current. A new input from v_g with a transfer function $H_c(s)$ is introduced at the summing junction in order to cancel the undesired voltage term in (3) as shown in Fig. 9.

From Fig. 9(b), the total input admittance of the converter is,

$$Y(s) = \frac{i_g(s)}{v_g(s)} = \frac{G_v}{1+T_i} + \frac{G_d F_m H_i}{1+T_i} k_v Y_c h_v + \frac{G_d F_m H_i}{1+T_i} H_c h_v + Y_{Ci} \quad (9)$$

According to (9), equation (5) is modified into,

$$Y(s) = Y_1(s) + Y_2(s) + Y_3(s) + Y_{Ci}(s) \quad (10)$$

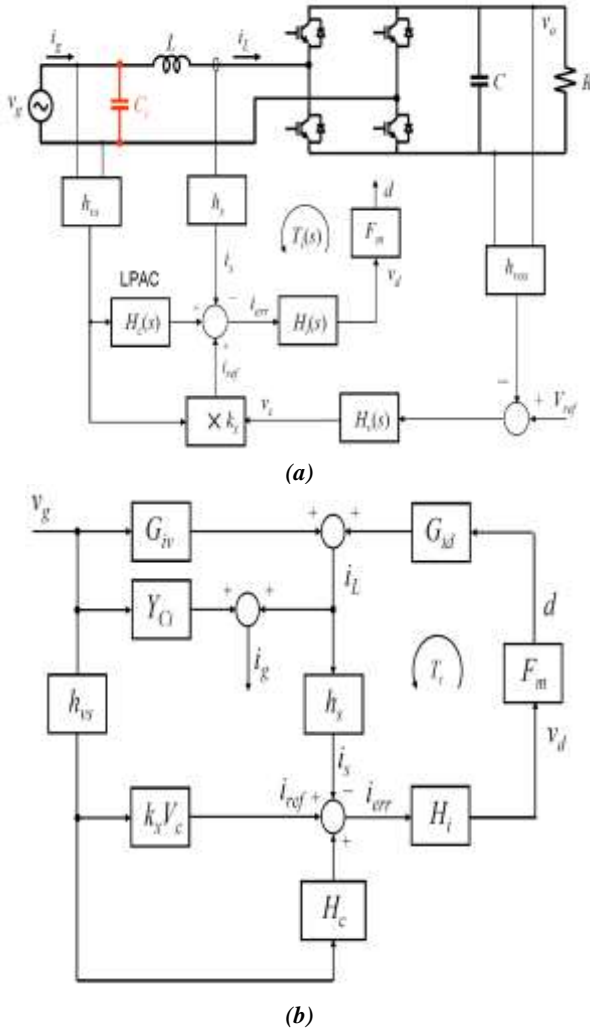

Fig 9: Full-bridge PFC converter with an input filter capacitor and LPAC

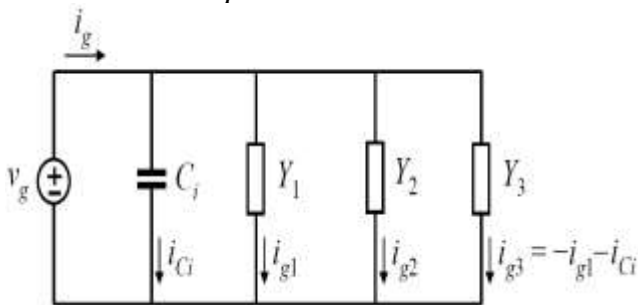

Fig 10: Input admittance of the converter with LPAC

Below the current loop crossover frequency, neglecting r and using the $Y_3(s)$ to cancel the effect of $Y_1(s)$ and $Y_{Ci}(s)$,

$$Y_3(s) = \frac{H_c h_{ver}}{h_s} = -(Y_1(s) + Y_{Ci}(s)) \quad (11)$$

From (11), the LPAC transfer function is given as

$$H_c(s) = -\frac{1 + 2V_o F_m \omega_c C_i h_v}{2V_o F_m h_{vs}} \frac{s}{\omega_c \left(1 + \frac{s}{\omega_c}\right)} \quad (12)$$

As shown in Fig. 10, $Y_3(s)$ draws a current opposite to the current $Y_1(s)$ and $Y_{Ci}(s)$ and, thus, cancels its effects at frequencies within current loop bandwidth. The result in Fig. 11, demonstrate that the frequency range of undistorted current operation is drastically extended for more than a decade.

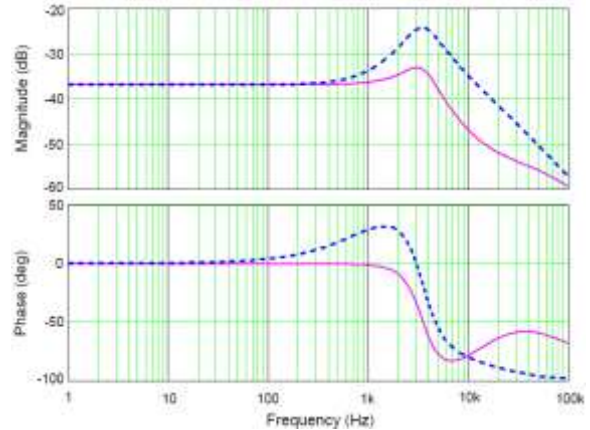

Fig. 11 Close loop input admittance with LPAC
Dash—uncompensated, Solid—LPAC-compensated

Implementation of the LPAC

A generic implementation of the LPAC in a standard PFC control system is shown in Fig. 12. $H_c(s)$ is part of the compensator circuit; it is added to the system by means of an R_C-C_C network from the rectified line voltage to the negative input of the current loop amplifier.

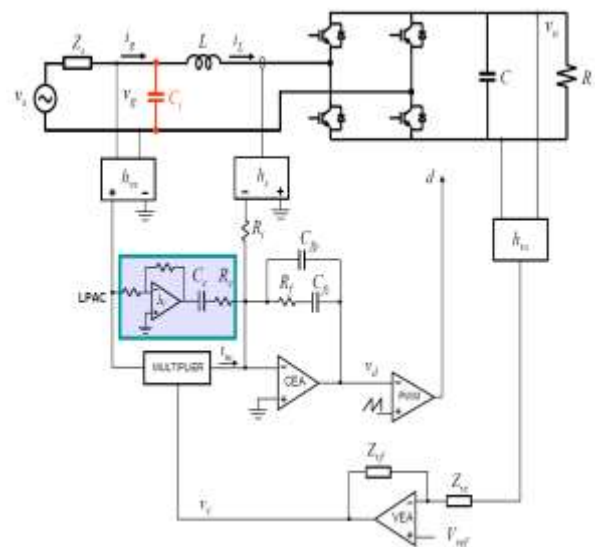

Fig 12: Implementation of the bidirectional PFC converter with LPAC

Assume for generality that the R_C-C_C Circuit is connected to v_g through a gain h_c of LPAC network amplifier. Then,

$$H_c(s)H_i(s) = \frac{v_d(s)}{v_g(s)} = \frac{h_c \left(R_f + \frac{1}{sC_p} \right) \parallel \frac{1}{sC_{fp}}}{R_c + \frac{1}{sC_c}} \tag{13}$$

$$H_c(s) = \frac{C_c h_c}{C_{fp} + C_c} \frac{s}{\omega_c \left(1 + \frac{s}{\omega_c} \right)} \tag{14}$$

Where $\omega_c = \frac{1}{C_c R_c}$ (15)

Comparing equations (12) and (14), we obtain

$$\omega_c = \omega_z, \quad R_c = \frac{1}{C_c \omega_z} \tag{16}$$

$$C_c = \frac{C_{fp} + C_p}{2V_o F_m h_c h_v} (1 + 2V_o F_m \omega_c C_i h_z) \tag{17}$$

Eq.(16) and Eq.(17) shows that the achieved compensation of current phase lead is load invariant and line frequency invariant.

Thus in such a manner, the LPAC can be used to cancel C_i current as well such as the total current is in phase with the line voltage (Fig. 13), and the converter truly operates with unity power factor. The voltage and current waveforms of the converter without and with LPAC are shown in Fig. 13 (a) and (b) respectively.

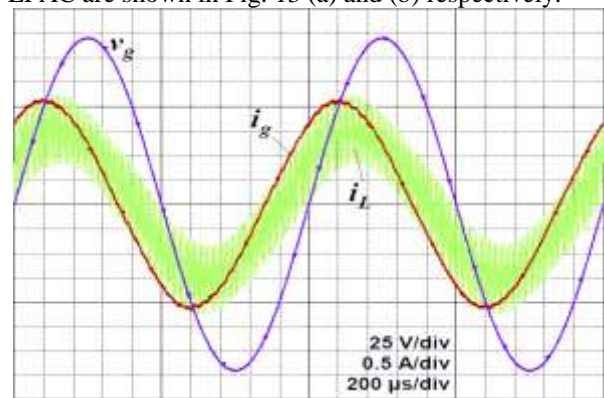

(a)

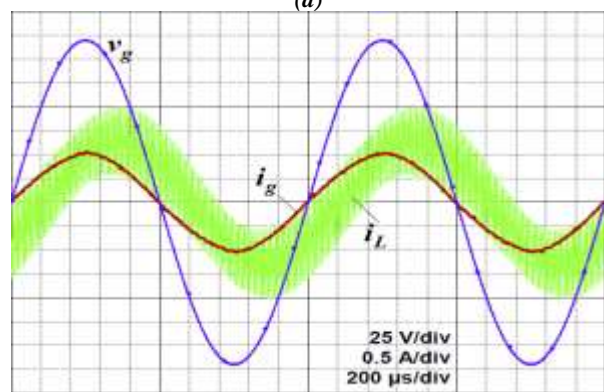

(b)

Fig. Bidirectional PFC converter operation (a) without and (b) with LPAC-compensator

fac = 500 Hz, fsw = 90 kHz, Ci = 1.5 μF, Po = 100 W

Shunt active power filter

Shunt active power filter is an important and recent application of Bidirectional PFC boost converter.

For a single phase power supply, most economical, traditional Peak detection method is now replaced by Average Current-Mode Control technique. A typical block diagram of Shunt Active Power Filter using ACMC with LPAC is shown in Fig. 14.

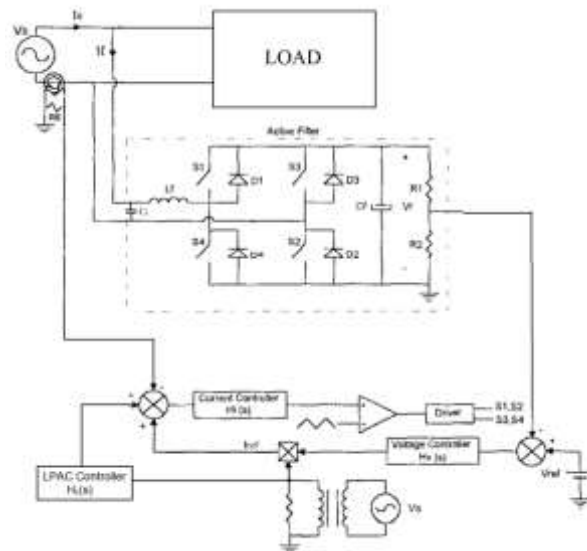

Fig 14: Shunt Active Power Filter

The shunt active power filter is used for reactive power and harmonic compensation of power supply. Active filter using ACMC with LPAC has many advantages over traditional Peak detection method.

- It required only one voltage and current sensor.
- Good control on reactive power regulation.
- Dynamic response has been improved.
- Also applicable for higher line frequency supply.
- It has very low Switching noise.

Conclusion

Due to the slower switching speed of IGBTs, we are unable to use them in PFC boost converter with ACMC for higher line frequency power system. The lower switching speed causes zero-crossing distortion which reduced the performance of PFC and harmonic reduction.

This problem can be solved by LPAC compensation which also takes in account the effect of input filter capacitor and keeps power factor very close to unity.

This method also enables to use Active Power Filter using ACMC for higher frequency power system.

Acknowledgments

I would like to thank VIVA Institute of Technology to give me this opportunity. I would also like to thank my fellow friend Mr. Ankit Deshpande for being my advisor and his valuable help to work better.

References

1. M. H. Rashid, *Power Electronics Handbook*, New York: Academic Press, 2001.
2. Z. Salam, T. P. Cheng & A. Jusoh, "Harmonic Mitigation Using Active Power Filter: A Technology Review", *Elektrika*, Vol. 8, No. 2, pp. 17-26, 2006.
3. C. Zhou & M. M. Jovonovic, "Design Trade-offs in Continuous Current-Mode Controlled Boost Power-Factor Correction Circuit", *HFPC, Proceedings 209*, 1992.
4. D. A. Torrey, A. Al-Zamel., "Single-phase active power filters for multiple nonlinear loads," *IEEE Transactions on Power Electronics*, Vol. 10, pp. 263-271, 1995.
5. Roma Dash, "Power Factor Correction Using Parallel Boost Converter", B. Tech. thesis, *Electrical Engineering, National Institute of Technology, Rourkela, India*, 2011.
6. K. P. Louganski, "Generalized Average-Current-Mode Control of Single-Phase AC-DC Boost Converters with Power Factor Correction", Ph.D. thesis, *Electrical Engineering, Virginia Polytechnique Institute & state University, Blacksburg, Virginia*, 2007.
7. J. P. Noon, "Designing high-power factor off-line power supplies," *2003 Unitrode Design Seminar Manual, SEM1500, Texas Instruments*, 2003.
8. K. P. Louganski and J.-S. Lai, "Current phase lead compensation in single-phase PFC boost converters with a reduced switching frequency to line frequency ratio," *IEEE Trans. Power Electron.*, vol. 22, no. 1, pp. 113-119, January 2007.
9. J. Sun, "Input impedance analysis of single-phase PFC converters," *IEEE Trans. Power Electron.*, vol. 20, pp.308-314, March 2005.
10. R. Patidar, "A Single-Phase Hybrid Filter to Improve Power Quality," *XXXII National Systems Conference, December 17-19, 2008*.
11. H. Akagi "Active and hybrid filters for power conditioning," *Proceedings of 2000 IEEE International Symposium on Industrial Electronics*, vol.1 pp. 26-36, 2000.
12. N. Devarashetti, Y. Reddy, P. Kishor, "Design and simulation of Hybrid Active Power Filter using the Adaptive Fuzzy Dividing Frequency-Control Method," *IJSER*, vol.2, Issue 12, December 2011.
13. L. S. Czarnecki, "An Overview of Methods of Harmonic Suppression in Distribution Systems," *Proceedings of the IEEE Power Engineering Society Summer Meeting, Washington, USA, 2000*, pp. 800-805.
14. K. Nishida, M. Rukonuzzman and M. Nakaoka, "Advanced Current Control Implementation with Robust Deadbeat Algorithm for Shunt Single-Phase Voltage-Source Type Active Power Filter," *Proc. IEE Electric Power Applications*, vol. 151, no. 3, pp. 283-288, 2004.
15. T. -F. Wu, C. -L. Shen, C. H. Chang and J. -Y. Chiu, "1/spl phi/ 3W Grid-Connection PV Power Inverter with Partial Active Power Filter," *IEEE Trans. on Aerospace and Electronic Systems*, vol. 39, no. 2, pp. 635-646, 2003.